



2016

College of Engineering and Technology Research Project Guidebook – Thesis Writing



Engr. Reynaldo Perez-Ramos, PhD
College of Engineering and Technology
ROMBLON STATE UNIVERSITY

MIMAROPA Region
PHILIPPINES

10/14/2016

Total Top Margin: 2"

Top Margin: 1"
LETTER SIZE BOND PAPER

4 single spacing, **12 font size,**
TIMES ROMAN or ARIAL, BOLD

UTILIZATION OF RICE HUSK ASH AS AN ADDITIVE IN BRICKS

Left Margin: 1.5"

6 single spacing, 12 font

Right Margin: 1"

**A Research Proposal Presented to the
Faculty of the College of Engineering and Technology
Romblon State University
Odiongan, Romblon**

6 single spacing, 12 font size

**In Partial Fulfilment of the Requirements for the Degree
Bachelor of Science in Civil Engineering**

By

**Blasurca, Marco G.
Familara, Shiela Jane D.
Gregorio, Ma. Salve G.
Manalon, Jake Emelito G.
Rubion, Arvilyn S.
Rubion, Joven M.
Tadia, Jane Angelique F.**

1 single spacing

October 2016

Bottom Margin: 1"

Top margin: 1"

APPROVAL SHEET

2 single spacing, 12 font size, justified

Left Margin: 1.5"
Justified, single spacing

The thesis entitled, "TITLE OF THE STUDY IN BOLD CAPITAL LETTERS", prepared and submitted by NAMES OF THE STUDENT RESEARCHERS (COMPLETE SURNAME, FIRST NAME INITIALS, MIDDLE INITIALS; RAMOS, R.P.) IN BOLD CAPITAL LETTERS, in partial fulfilment of the requirements for the degree of Bachelor of Science in Civil Engineering is hereby accepted for oral examination.

3 single spacing, 12 font

Right Margin: 1"

ENGR. REYNALDO P. RAMOS, PhD
Chairman, Panel of Examiners

ENGR. ORLEY G. FADRIQUEL
Member, Panel of Examiners

3 single spacing, 12 font size

ENGR. APRILLE ANN M. SIM, M'Eng
Member, Panel of Examiners

ENGR. JASON F. RUFON, MAPA
Adviser

3 single spacing, 12 font size

Approved and accepted as partial fulfilment of the requirements for the degree of BACHELOR OF SCIENCE IN CIVIL ENGINEERING.

3 single spacing, 12 font size, center

ENGR. APRILLE ANN M. SIM, M'Eng
Chairman, Civil Engineering Department

3 single spacing, 12 font size, center

ENGR. ORLEY G. FADRIQUEL
Dean, College of Engineering and Technology

Date: _____

Bottom margin: 1"

ACKNOWLEDGMENT

Top margin: 1"

iii

Paging, bold

2 spacing, 12 font size, justified, double

The students would like to express their gratitude and since thanks to the people

who assisted and guided them in making this research proposal successful. **(LIMIT TO**

ONE PAGE ONLY).

Left Margin: 1.5"

Right Margin: 1"

Blasurca, M. G.

Familiara, S. D.

Gregorio, Ma. S. G.

Manalon, J. E. G.

Rubion, A. S.

Rubion, J. M.

Tadia, J. A. F.

Bottom margin: 1"

Top margin: 1"

iv

TABLE OF CONTENTS

Left Margin: 1.5"

2 single spacing, 12 font size, justified

Right Margin: 1"

Contents		Page
TITLE PAGE		i
APPROVAL SHEET		ii
ACKNOWLEDGMENT		iii
TABLE OF CONTENTS		iv
LIST OF TABLES		v
LIST OF FIGURES		vi
LIST OF APPENDICES		vii
ABSTRACT		viii
CHAPTERS		
I	INTRODUCTION	1
	Background of the Study	1
	Objective of the Study	3
	Significance of the Study	4
	Scope and Delimitation of the Study	6
II	REVIEW OF RELATED LITERATURE	7
	Related Literature	7
	Related Studies	10
	Conceptual Framework	11
	Definition of Terms	13
	Hypothesis of the Study (if applicable)	14
III	RESEARCH METHODOLOGY	16
	Research Materials	16
	Research Equipment	17
	Research Locale and Time of Study	18
	Research Methods	20
IV	RESULT AND DISCUSSION	22
	Result of the Experiment	22
	Statistical Data and Result	23
	Testing Performance	26
	Financial Analysis (if applicable)	30
V	SUMMARY, CONCLUSION AND RECOMMENDATION	31
	Summary	31
	Conclusion	32
	Recommendation	35
REFERENCES		36
APPENDICES		37

Use Tab for alignment, single spacing

Bottom margin: 1"

Top margin: 1"

LIST OF TABLES

2 spacing, 12 font size, center

Left Margin: 1.5"

Title

single spacing, 12 font size, justified

Page

Right Margin: 1"

1	List of Materials	16
2	List of Equipment	17
3	Mixture of the Samples	22
4	Test Results of Compressive Strength	23
5	Test Results of Water Absorption	24
6	Mean Values of Test Results	25

Indent, 1 Tab

Use Tab for alignment

Bottom margin: 1"

Top margin: 1"

LIST OF FIGURES

2 spacing, 12 font size, iustified

Left Margin: 1.5"

Title

Page

1	Input-Output-Process	11
2	Materials Used	16
3	Grinding of Rice Husk Ash	17
4	Mixing of Materials	20
5	Comparison of the Performance	26

Right Margin: 1"

Indent, 1 Tab

Use Tab for alignment

Bottom margin: 1"

Top margin: 1"

LIST OF APPENDICES

2 spacing, 12 font size, justified

Left Margin: 1.5"

Title

Page

1	Input-Output-Process	11
2	Materials Used	16
3	Grinding of Rice Husk Ash	17
4	Mixing of Materials	20
5	Comparison of the Mixtures and Performance	26

Indent, 1 Tab

Use Tab for alignment, single space

Right Margin: 1"

Bottom margin: 1"

Top margin: 1"

UTILIZATION OF RICE HUSK ASH AS AN ADDITIVE IN BRICKS

2 single spacing, 12 font

Title, centered, bold Times Roman or Arial, 12 font size

Marco G. Blasurca, Shiela D. Familara, Ma. Salve Gregorio, Jake Emelito Manalon, Arvilyn Rubion, Joven Rubion, Jane Angelie F.

2 spacing, 12 font size

ABSTRACT

2 spacing, 12 font size

Indent, 1 Tab, double spacing, justified

The abstract is a brief and concise descriptive summary of the study which contains the statement of the problem or the main objective of the study, research design, significance of the study, research instruments, techniques, data gathering procedure, data processing method, findings, conclusions, and **NO RECOMMENDATIONS.**

LIMIT TO 1-2 PAGES FOR THE ABSTRACT – MAXIMUM OF 250 WORDS.

Left Margin: 1.5"

Right Margin: 1"

Bottom margin: 1"

Top margin: 1"

CHAPTER I

Indent, 1 Tab, justified

2 Double spacing, 12 font size

INTRODUCTION

This chapter presents the background of the study, objectives of the problem, significance of the study, scope, and delimitation of the research study.

2 double spacing, 12 font

BACKGROUND OF THE STUDY

This section of the report provides the overview discussion of the study, particularly the research problem – the “rationale” (basis, motivation, justification) of doing the research. Highlights of the related literature review are included in this section by citing important phrases and sentences from relevant secondary sources of information. This will also provide the reader general idea and impression about the topic under study.

2 double spacing, 12 font size, justify

STATEMENT OF THE PROBLEM/OBJECTIVES OF THE STUDY

The statement of the research problem must be brief but comprehensive and should have practical importance. A good problem statement is concerned with relation between two or more variables. It is stated clearly without ambiguity and is capable of empirical testing. Thus, the statement of the problem is in a simple language. It is specific, clear and limited. It directs the researcher and the research process, and suggests a specific answer or conclusion. It is the “verbalization of the “questions” which the study proposes to answer.

Bottom margin: 1"

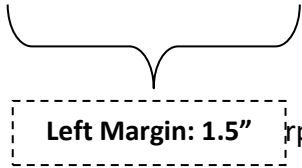
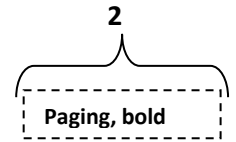
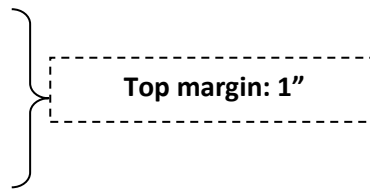

On the other hand, the main objective of the research study is a statement of purpose because this is the guide to be accomplished by the researcher in conducting the research.

Example A: *The main objective is to analyze and evaluate the electrical system of the main campus of Romblon State University (RSU). Specifically, it attempts to answer the following research questions:*

- (1) *What is the total load capacity of the transformers that can hold the power requirements of the RSU-main campus?*
- (2) *What is the total power rating used in the university?*
- (3) *How to maximize and minimize the loading capacity used in the university?*

Example B: *This study aims to design and develop an inlet valve using Bluetooth technology. In particular, the study attempts to answer the following research questions:*

- (1) *What is the distance of the blue-valve from the Bluetooth technology for water supply control system application in both residential and commercial buildings?*
- (2) *What is the cost in the application of Bluetooth technology for water supply control system?*
- (3) *What the level of performance of the developed water supply control system?*

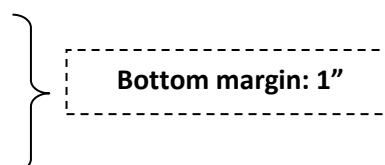
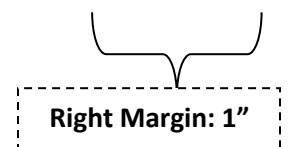

Top margin: 1"

SIGNIFICANCE OF THE STUDY

Left Margin: 1.5"

This section of the report explains the contributions of the study either to a body scientific knowledge, to practitioners/researchers in the same area of the research, or to any other group (students, local community, etc.) which benefit from the outcomes or results of the study. In other words, this answers the following questions: Why is it important for the research study to be conducted? Who will benefit from it, and what benefits could be derived from the results of the study? The research should clearly explain the intention of the researcher, the relevance, and the important implications of the study in solving a problem or a need of the society or community, knowledge gaps, or enriching existing research instruments and methods.

2 double spacing, 12 font size, justify

SCOPE AND DELIMITATION OF THE STUDY

This section explains the coverage of the study area, the subject being focused by the study, the research instruments or methods, duration of the study, and the constraints or limitations that have direct implication on the result of the study.

Bottom margin: 1"

Top margin: 1"

CHAPTER II

Indent, 1 Tab, justified

2 double spacing, 12 font size, centered

LITERATURE REVIEW

This chapter presents the legal bases, literature, and studies which are relevant to the research study. The main purposes of the literature review are (a) to determine the similarities and differences of the on-going study and past studies; (b) to acquire additional insights and ideas related to the problem being addressed in the study. Observe proper referencing or citation of the sources of information, using the American Psychological Association (APA) styles to avoid copying or "plagiarism" or infringement. Plagiarism is a violation of Republic Act 8293 known as the Intellectual Property Code of the Philippines. This act provides legal basis in proper use of passages, writings, ideas and statements of other authors/writers by giving due credit of their work.

2 double spacing, 12 font size,

RELATED LITERATURE

This sub-section of the literature review covers those related literature from published articles, books, journals that have connection or linkages to the study conducted (Ramos, 2015; Ramos et al., 2011).

2 double spacing, 12 font size,

RELATED STUDIES

The sub-section covers published and unpublished research works which are related to the study. According to Ramos (2011), it is necessary to highlight the significant findings from these researches that have similarities and differences to the

Bottom margin: 1"

} **Top margin: 1"**

on-going study. The present or current and latest related studies are presented first, then following by those past ones. Please note that **Wikipedia source is not allowed.**

} 2 double spacing, 12 font size,

CONCEPTUAL FRAMEWORK

This section explains both the theoretical and conceptual framework of the study. It gives a clear discussion regarding the research paradigm used in the conduct of the study. A typical model is the **INPUT-PROCESS-OUTPUT** which constitutes the flow of the activities, including the relationship of selected variables.

} 2 double spacing, 12 font size,

} **Right Margin: 1"**

SYNTHESIS

This contains summary of the review of past studies that are relevant to the present conduct of the study. It is worth mentioning the methods, procedures, and framework adopted from the literature.

} 2 double spacing, 12 font size,

DEFINITION OF TERMS

This is to enumerate the key terms used in the study and it is recommended to use the "operational term" in defining these key terms. It is operational term when it is based on an observed characteristic and how this term is used in the study.

} 2 double spacing, 12 font size,

Inlet – it is a tube or hollow cylinder used to convey materials or as a structural component.

Pressure – it is the energy that the system needs to deliver the water.

} 2 double spacing, 12 font size,

HYPOTHESIS OF THE STUDY (IF APPLICABLE)

} **Bottom margin: 1"**

} **Top margin: 1"**

No page #

CHAPTER III

} 2 double spacing, 12 font size,

Indent, 1 Tab, justified

RESEARCH METHODOLOGY

This chapter presents the methodology used in the study, including the materials and equipment or instruments used, selection of respondents (if applicable, and instruments (questionnaire, case study), and the overall procedures in the data collection and the statistical treatment of the data collected.

} 2 double spacing, 12 font size,

RESEARCH MATERIALS

} 2 double spacing, 12 font size,

} **Right Margin: 1"**

} **Left Margin: 1.5"**

RESEARCH EQUIPMENT

} 2 double spacing, 12 font size,

RESEARCH LOCALE AND TIME OF STUDY

} 2 double spacing, 12 font size,

RESEARCH METHODS

} **Bottom margin: 1"**

} **Top margin: 1"**

No page #

CHAPTER IV

} 2 double spacing, 12 font size,

Indent, 1 Tab, justified

RESULT AND DISCUSSION

This chapter presents the important findings of the study. Findings should answer the research questions as stated in **Chapter 1** or answering the research objectives.

} 2 double spacing, 12 font size,

RESULT OF THE EXPERIMENT

} 2 double spacing, 12 font size,

STATISTICAL DATA AND RESULT

} 2 double spacing, 12 font size,

} **Left Margin: 1.5"**

} **Right Margin: 1"**

TESTING OF PERFORMANCE

} 2 double spacing, 12 font size,

FINANCIAL ANALYSIS (IF APPLICABLE)

} Double spacing, 12 font size,

Tables (title is placed on top) and figures (title is placed at the bottom) should be carefully explained in the text and cited in numerical order. Use basic colors in the figures, charts, and diagrams (**Table 1**). **Table entries are between 10-12 font size.**

Table 1. Tables and figures should be valuable, relevant, and visually attractive.

Heading	Heading	Heading	Heading
Component			
Component			
Component			
Total			

} **Bottom margin: 1"**

Top margin: 1"

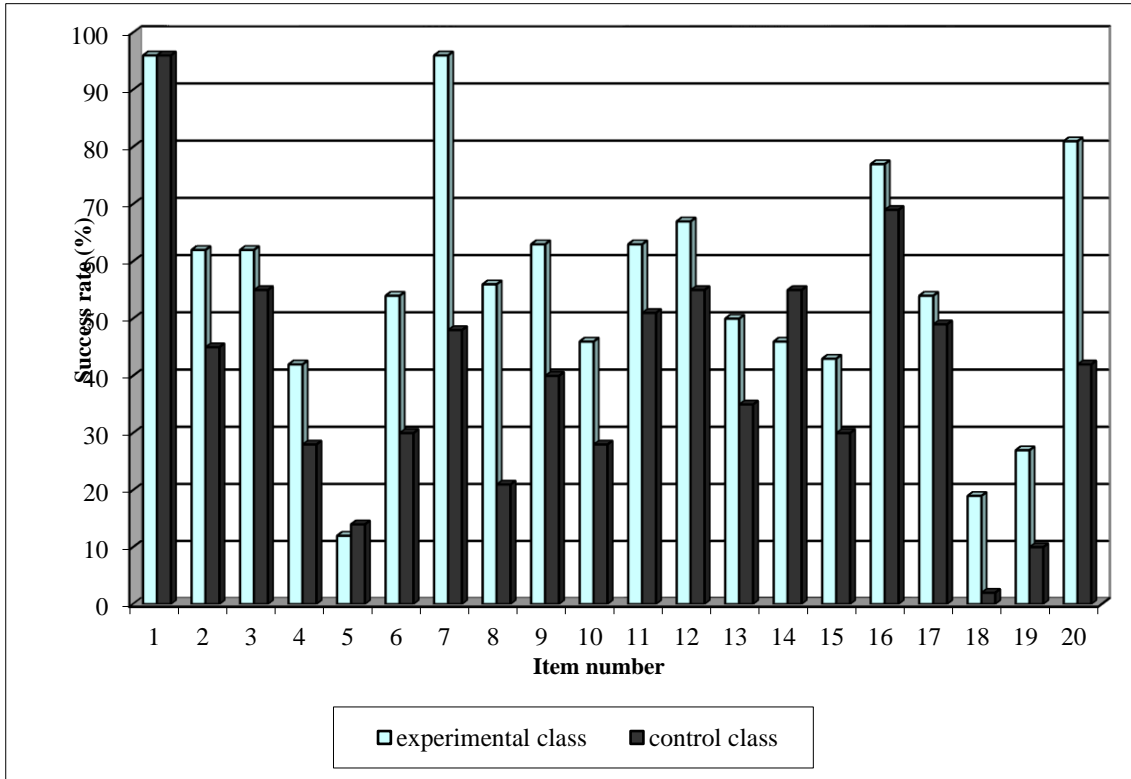
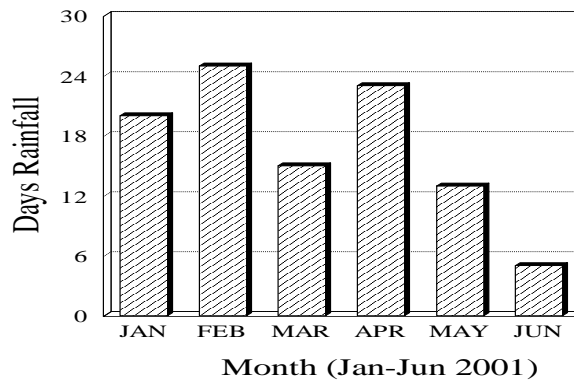

Figure 1. Comparison of success rate of items in the experimental and control class

Figure 2 shows the daily rainfall from January to June. The highest rainfall occurred in February then followed in April.

Left Margin: 1.5"



Right Margin: 1"

Figure 2: Clear line drawings are essential

Bottom margin: 1"

Top margin: 1"

No page #

CHAPTER V

Indent, 1 Tab, justified

2 double spacing, 12 font size,

SUMMARY, CONCLUSION AND RECOMMENDATION

This chapter presents the highlights of the key results of the study, including the recommended future researches towards for further investigations.

2 double spacing, 12 font size,

SUMMARY

Summary should be based on the major findings or results of the study which answer the research questions as stated in Chapter 1 or answering the research objectives.

2 double spacing, 12 font size,

CONCLUSION

Conclusions should be based on the major results that have contributions to the body of knowledge

2 double spacing, 12 font size,

RECOMMENDATION

Left Margin: 1.5"

Right Margin: 1"

Bottom margin: 1"

Left Margin: 1.5"

Top margin: 1"

Right Margin: 1"

REFERENCES

2 double spacing, 12 font size,

- Ramos, R. P. (2015). *Title of the Book*. City, Country: Publisher. (example citation from a book)
- Ramos, R. P. (2014). Title of the Article. *Name of the Journal*, Volume (Nos.), pages. (example citation of a journal)
- Ramos, R. P. (2016). Research Methodology. Retrieved from <http://www.bolender.com/action.htm> (example of citation from an online source)
- Castillo, F.S. (2007). *Research Education and Scientific Writing* (Latest Ed.). Manila, Philippines: Booklore Publishing Corporation (from a book with one author)
- Sha, A. S. (2011). *Research Methodology*. New Delhi, India: A P H Publishing Corporation (from a book with one author)
- Paler-Calmorin, L. & Calmorin M. A. (2007). *Research Methods and Thesis Writing*, (Second ed.). Manila, Philippines: Rex Printing Company, Inc. (from a book with two authors)
- Ramos, R. P. (2011). *Analysis of Mixed-use Schemes in Regeneration Areas*. Ph.D dissertation, Faculty of Art, Design and the Built Environment, University of Ulster (example of citation from PhD dissertation)
- Dela Vega, M., Gado, J. R., Galanga, C. M., Gaytano, G. F., Marcelo, E. S., Mayor, K. F., Mindoro, A. M., Morines, C. B., Motin, M. E., Overio, C S., & Teologo, R. G. (2016). *Bluetooth Application for Water Supply Control System*. Master thesis, College of Engineering and Technology, Romblon State University (example of citation from a Master's thesis)
- Romblon State University (2010). *Research Manual*, Unpublished, Philippines: Romblon State University, Romblon.

Bottom margin: 1"

Top margin: 1"

APPENDICES

2 double spacing, 12 font size,

DOCUMENTATION

Include photographs, figures, tables, diagrams, charts, test results, standard procedures, programming, plans and drawings, with proper captions or titles.

Double spacing, 12 font size,

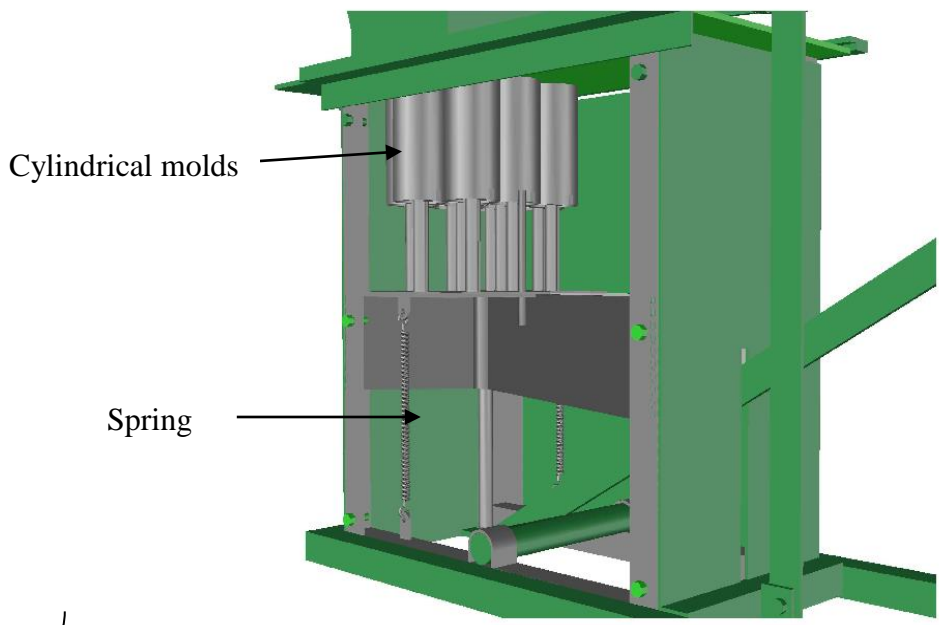

The Briquetting chamber

Left Margin: 1.5"

2 double spacing, 12 font size,

Right Margin: 1"

BIOGRAPHICAL SKETCH

This includes a brief profile of the student researchers with clear 2x2 photo size, with signature specimen of the student.

2 double spacing, 12 font size,

CERTIFICATE OF ENGLISH CRITIC

A certification from an English teacher that the report is properly checked to meet University's technical writing standards.

SIDE OF THE BINDED THESIS (RED COLOR)

FRONT COVER OF THE BINDED THESIS (RED COLOR WITH LAMINATION)

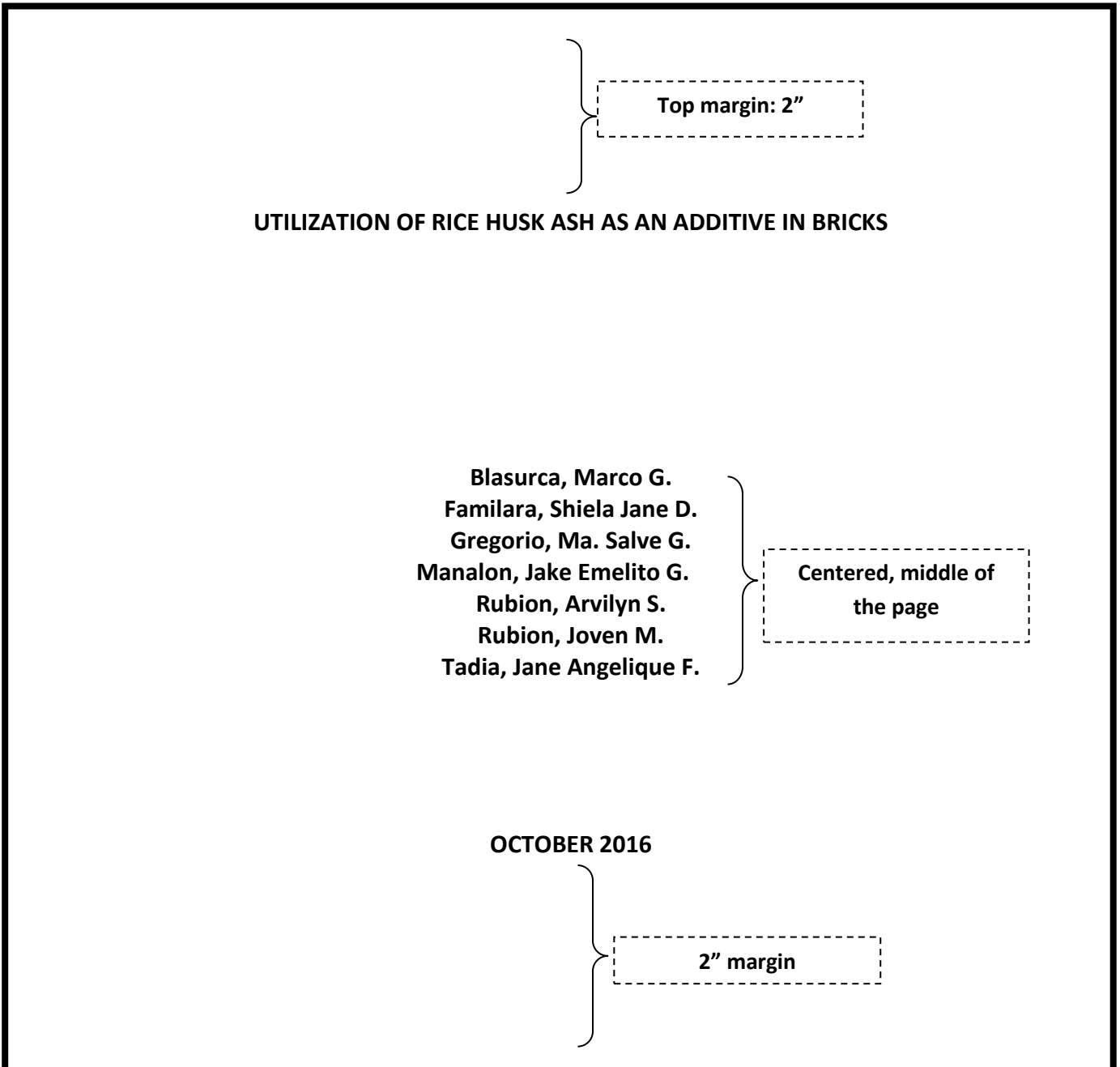

The succeeding pages are extracted from the Romblon State University's Research Manual covering the general guidelines for the report form and style, including samples of the American Psychological Association (APA) format of references.

Romblon State University Odiongan, Romblon	Form. Title: RESEARCH REPORT FORM & STYLE	
	Form No.: RSU-URC FORM-08	Rev. No.:2
	Effectivity Date:	Page 1 of 20

1. General Document Guidelines

- A. *Paper*: Substance 20, 8½" x 11" white, one side only
- B. *Margins*: 1½ left, one inch right, top and bottom margins
- C. *Font Size and Type*: ^{arial} Times New Roman, 12-pt Font
- D. *Spacing*:
 Body- double space
 Headings- between level 5 and level 1, 3 spaces; level 1 and level 2, 3
 Spaces; end of paragraph and level 3, 3 spaces; last line of paragraph
 And level 4 (paragraph heading), 2 spaces
- E. *Alignment*: Flush left (unjustified) ^{justify}
- F. *Paragraph Indentation*: ½ inch
- G. *Pagination*: Preliminary pages are numbered in small roman numerals in the lower part at the center. The page number of the chapter pages up to the appendices appears in the upper right-hand. The only pages that are not numbered are Figures and the first page of all preliminary sections and chapters.
- H. *Order of Topics*: Order the presentation of topics as follows:
1. For undergraduate research, project report, master's thesis and doctoral dissertation:

PRELIMINARY PAGES

Title Page, Approval Page, Acknowledgement, Table of Contents, List of Tables, List of Figures, Abstract

CHAPTERS

I INTRODUCTION

II REVIEW OF RELATED LITERATURE

**III METHODOLOGY/MATERIALS AND
METHODS/METHODS AND PROCEDURES**

IV RESULTS AND DISCUSSION

- a. Findings
- b. Discussion

**V SUMMARY, CONCLUSIONS, IMPLICATIONS (for theory,
Practice, and policy if applicable) and Recommendations**

**REFERENCES
APPENDICES**

2. For URC funded researches:

PRELIMINARY PAGES

Title Page: Acknowledgements, Table of Contents, List of Tables, List
Of Figures, Abstract

CHAPTERS

I INTRODUCTION- to include background, rationale and related
Literature; objectives; hypothesis, theoretical and conceptual
Framework, operational definition of variables (if applicable);
Significance of the study; scope and limitation of the study

**II METHODOLOGY/MATERIALS AND METHODS/METHODS
AND PROCEDURES**

III RESULTS AND DISCUSSION

- a. Findings
- b. Discussion

**IV SUMMARY, CONCLUSIONS, IMPLICATIONS,
RECOMMENDATIONS (for theory, practice, and Policy if applicable)**

REFERENCES APPENDICES

Title Page

- A. *Key Elements*: Paper Title, author (s), institutional affiliation (s), date completed
- B. *Paper Title*: UPPER CASE, centered, inverted pyramid
- C. *Author (s)*: Title Case, centered
- D. *Institutional affiliation*: Title case, centered
- E. *Example of RSU- suggested Title Page*: **Appendix A** (for Dissertation, Thesis, Special Paper, and Project Report), **Appendix B** (for URC-funded researches)

ABSTRACT

The abstract is a one-paragraph, self-contained summary of the most important elements of the paper.

- A. *Pagination*: The abstract begins on a new page
- B. *Key Elements*: Paper Title, author (s)
- C. *Paper Title*: Upper letters, double space, centered
- D. *Author (s)*: Uppercase and lowercase letters, centered, 3 single spaces below the title.
- E. *Heading*: ABSTRACT (Uppercase letters, centered, 3 single spaces below the author.
- F. *Format*: The abstract begins on the line following the Abstract heading. The abstract should not exceed 250 words. It contains the objectives, the methods used, the results and conclusions (no recommendation). Sample ABSTRACT is shown in **Appendix C**.

Body

- A. *Pagination*: Each chapter of the paper begins on a new page. Page Number shall be in Arabic numbers. Page number is not written on the first page of each chapter. Subsections of the body of the paper do *not* begin on new pages.
- B. *Title*: The chapter number and the title of each chapter (in uppercase bold letters) are centered.
- C. *The Headings and Subheadings*: Headings and subheadings are necessary to help organize the different sections of the paper. Headings act similar to an outline. Articles in APA journals use from one to five levels of headings.

APA Headings

Level 5:

CENTERED UPPERCASE HEADING

Level 1:
Centered Title Case Heading

Level 2:
Centered, Italicized, Title Case Heading

Level 3:
Flush Left, Italicized, Title Case Heading

Level 4:
Indented, italicized, lowercase paragraph heading ending with a period.

For many papers in **APA** style, two levels of headings meet the requirements (use levels 3 & 4). When three levels of headings are needed, use levels 2, 3, & 4. Example of **APA** headings and subheadings is shown in **Appendix D**.

D. On the Use of Abbreviations: In general, avoid the use of abbreviation and symbols in the text. However, abbreviation of units of measure is allowed if it follows an exact number. An abbreviated unit of measure does not have a plural form and not punctuated with a period. A period after an abbreviation is required for words which have equivalent in the English language such as: in. for inches, gal. for gallons.

E. On numbers:

- e. 1. Spell out stand-alone fractions but write in numerals fractions followed by a unit of measure (Example: one-fourth of the class, but $\frac{1}{4}$ in.).
- e.2. Spell out numbers at the beginning of a sentence.
- e.3. Spell out numbers below 10 but write in numerals in a series even if they are below 10 (three apples but 3 apples, 4 bananas, and 2 oranges).
- e.4. Use numerals for lower numbers grouped with numbers 10 and above (for example, from 6 to 12 hours of sleep).
- e.5. To make plurals out of numbers, add *s* only, with no apostrophe (the 1950s). back modifiers (five 4-point scales) and for large sums (over 3 million people).
- e.7. Use percent symbol (%) only with figures (5%) not with written numbers (five percent).

F. Tables and Figures: Tables shall have open sides without column lines (except where there are many columns) and without row lines (except on the heading and bottom part). Table entries shall be printed in 10-12 pt font size. Figures to present graphs, photographs, or other illustrations (other than tables) shall be centered. Figure caption(s) is centered at the first line (double space) below the figure and

type Figure 1. (or 2 Or 3, etc.) followed by the caption for the figure, capitalizing only the first letter of the first word and any proper nouns.

G. Examples of URC tables and figures are shown in **Appendix E**.

H. Text Citations: The citations that appear throughout the body of the text are necessary because they give credit to the original author. Both direct quotes and paraphrasing require citation. Citations include the author's last name and the year of publication (for quoted material, a page number is included). If an author is not available, use the title of the work. The punctuation for the end of the sentence ALWAYS follows the last parenthesis (See **Appendix F**). A direct quotation consisting of more than three lines should be written single space, indented let and right, separated from the main paragraph by three spaces, and enclosed in quotation (top and below).

References

All sources included in the References section are those cited in Chapters 1 and 2.

A. Pagination: The list of references begins on a new page.

B. Heading: The word References (in Title Case) should be centered at the top of the page and typed in regular font.

C. Format: Example of APA style of presenting different types of sources is shown in **Appendix G**.

Examples:

APA 5th edition guidelines. Retrieved February 18, 2003, from <http://www.uca.edu/divisions/academic/writing/OWL/LINKS/OnlineHandouts/apabasics.PDF>.

APA research style crib sheet. Retrieved July 25, 2003, from <http://www.wooster.edu/psychology/apa-crib.html>.

APA style essentials. Retrieved October 13, 2003, from http://www.vanguard.edu/faculty/ddegelman/index.cfm?doc_id=796

Romblon State University Odiongan, Romblon	Form title: PROGRESS REPORT	
	Form No.: RSU-URC FORM-07	Rev. No.: 0
	Effectivity Date: June 15,2010	Page 1 of 1

Date

The University Research Committee
Romblon State University
Odiongan, Romblon

My research, “_____” (research title) is presently on the (state present stage)_____. We will try our best to submit our final report on _____ (target date of completion).

Problem/s Encountered:

Assistance needed:

Very truly yours,

(Print Name and Signature of the Researcher(s))

Distribution List: URC file

APPENDIX A

(2 inches from the top)

**DESIGN, CONSTRUCTION AND PERFORMANCE TESTING OF A
LOW-COST GRAIN MOISTURE METER**

(6 single spaces)

A Special Paper

Presented to

The faculty of the School of Graduate Studies

Romblon State University

(6 single spaces)

In Partial Fulfillment

Of the Requirements for the Degree

Master in Engineering

By

Juan D. Cruz

March 2007 (1 inch from the bottom)

APPENDIX B

(2 inches from the top)

**ACCEPTABILITY AND SHELF LIFE OF INSTANT “GINATAANNG DARAG”
NATIVE CHICKEN TREATED WITH DIFFERENT
FOOD PRESERVATIVES**

A Research Report

Submitted to

The University Research Center

Romblon State University

Centered between
last lines of
the title and “BY”

By

Jaime C. Cabarles

December 2006 (1 inch from the bottom)

APPENDIX C

**BASELINE SURVEY ON THE WORK – LIFE ISSUES AND NEEDS OF THE WORK-
LIFE ISSUES AND NEEDS OF THE FACULTY AND STAFF OF CENTRAL
PHILIPPINES UNIVERSITY**

Randy A. V. Pabulayan	}	3 spaces
ABSTRACT	}	3 spaces

This study was conducted to know the wok-life issues and needs of the faculty and staff of the University. Descriptive analysis was employed and utilized the one- shot survey design. From a total of 630 employees, a sample of 239 was obtained using the sampling formula with a margin of error of 0.05. A self-administrated questionnaire served as the main tool for data collection. Results of the study showed that the majority of the respondent female, married, with a mean age of 41.8 years old and have been working with the University for 12.3 years. There are employees who admitted that their personal life responsibilities occasionally impede their job performance. They have been late for work more than once per month and could not concentrate with their job. Common reasons are financial concerns, family care, and child care. The employees believed that the University has existing work-life programs that have availed of it. Some employees reported that they have enjoyed a flexible work schedule, have availed of the University program employee health and well-being, and benefited from the University's financial assistance program. Among the work-life programs, financial assistance and family care are considered as very important. The employee health and well-being and personal convenience services are also regarded as important programs that could be implemented.

APPENDIX D

Operational Definition of Terms (Level 3 sub-heading)

To avoid and ensure a better understanding of the topics discussed, the important terms were defined conceptually and operationally.

Age. Refer to the length of the time in year a person has lived since he/she was born. In this study, it refers to the age of a respondent on his/her last birthday. In this study, it will be taken from medical records of Asilo de Molo. *(Level 4 sub-heading)*

Gender. Whether the older adult (OA) is male or female by birth. This will be taken from medical records of Asilo de Molo. *(Level 4 sub-heading)*

Educational Attainment. Refer to the level of education an individual has attained. In the study of refers to the highest grade/year completed by respondent. This was taken from medical records of Asilo de Molo. *(Level 4 sub-heading)*.

APPENDIX E-1

SAMPLE TABLES

Table 1. Distributed respondent According to Sex, Age, and Marital Status (N=239)

<u>Personal Characteristics</u>		<u>Frequency</u>	<u>Percent</u>
Sex	Male	80	33.5
	Female	159	66.5
	Total	239	100.0
Civil Status			
	Single	54	22.6
	Married	171	71.5
	Separated	3	1.3
	Widowed	9	3.8
	No Answer	2	0.8
	Total	239	100.0
Age	<31 y.o	42	17.6
	<31-40 y.o	61	25.5
	<41-50 y.o	53	22.2
	<51 y.o	53	22.2
	No Answer	30	12.6
	Total	239	100.0

Mean Age=41.8 years old

Table 2. Distribution of Potential Clients According to whether or not they are Alumni of RSU and whether or not they have Relatives who are RSU Alumni (N=77).

Connection with RSU Alumni	Frequency	Percent
Yes	29	37.7
No	48	72.3
Total	77	100.00
With Relatives who are Alumni		
Yes	56	72.7
None	21	27.3
Total	77	100.0

APPENDIX E-2

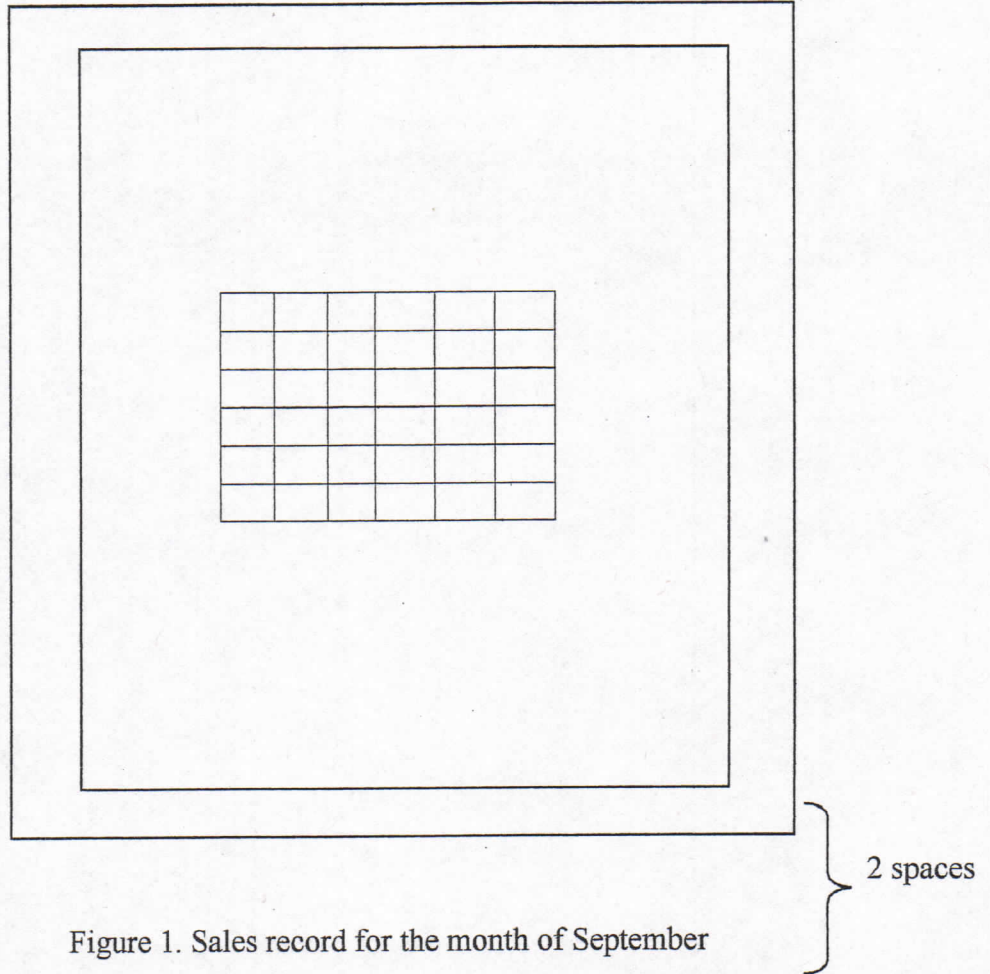

Figure 1. Sales record for the month of September

APPENDIX F

CITATION

- A direct quote (verbatim). (David, 1998, p. 276).
- Paraphrased text with one author. (David, 1998).
- Paraphrased text with two authors. (David & Pabulayan, 1998).
- . . . with three to five authors(first time only). . . (David, Dusaran, Jaco & Patricio, 1998)
- . . . with three to five authors(following the first time). . . (David et al.,1998).
- . . . with six or more authors. (David et al., 1998).
- With no author, use the first identifying words of the title. . . (“The Quest,” 1998).
- Citation from Internet source, no author. . . (from specific URL of a web page)
- Secondary citation. (Frondoza, 2003 in Reyes, 2005)

APPENDIX G

Samples of APA Formatted References

1. JOURNALS, MAGAZINES, NEWSPAPERS, ETC. (PERIODICALS)

General Form – Periodicals [Published in Print Format]:

Author, A. A., Author, B. B., & Author, C. C., (1999). Title of Article. Title of *Periodicals*, xx, xxx-xxx.

a. One Author

Importance, F. (2004). Self-concept related to scholastic achievement and selected Variables of high school students at Central Philippine University, SY 2001-2002. *Patubas: Multidisciplinary Research Journal of Central Philippine University* 2(1),58-74.

b. Two to Six Authors+Journal Paginated by Issue

Dusaran , R. and R. Pabulayan. 2005. Impact survey in the rural microfinance project of Taytay Sa Kauswagan, Inc. (TSKI) in the province of Antique. *Patubas: Multidisciplinary Research Journal of Central Philippine University*, 2(1), 89-102.

c. Six or More Authors

Wolchik, S. A., S.G. West, I.N. Sandler, J. Tein, D. Coatsworth, L. Lengua, et al. (2000). An experimental evaluation of theory-based mother and mother-child program for children of divorce. *Journal of Consulting and Clinical Psychology* 68,843-856.

d. Magazine Article

Belonio, A. (October 2006). Rice husk quasi gasifier stove with side-in steam injector for household use developed. *Agriculture Magazine*, 10(10), 59-60.

e. Review of a Book

Carmody, T.P. (1982). A new look at medicine from the social perspective [Review of the book *Social contexts of health, illness, and patient care*]. *Contemporary*

Psychology, 27,208-209.

f. Daily Newspaper Article + No Author + Discontinuous Pages

Generic Prozac debuts. (2001, August 3). *The Washington Post*, pp. E1, E4.

g. Newspaper Editorial

Stress, cops and suicide [Editorial]. (1993, December 1). *New York Times*, p. A22.

h. Editor + Entire Issue or Special Section

Bautista, M.L.S (1989). Code –switching studies in the Philippines. In B.P Sibayan & Gonzales, FCS (Eds), [special issue on sociolinguistic Studies in the Philippines]. *International Journal of Sociology of Languages*, 88, 19-32.

2. BOOKS, REPORT, BROCHURES, AV MEDIA, ETC (NONPERIODICALS)

General Form – Non-periodicals [Published in Print Format]:

Author, A. A. (1999). *Title of work*. Location: Publisher.

a. By a Single Author

David, F.P (2002). *Understanding and doing research: A handbook for beginners*. Iloilo City, Philippines: Panorama Printing, Inc.

b. By a Corporate Author + Published by Author

American Psychiatric Association. (1994). *Diagnostic and statistical manual of mental Disorder* (4th ed.). Washington, DC: Author.

c. By Anonymous Author

Guidelines and application form for directors, 1990 summer seminar for school teachers (1988). Washington, DC: National Endowment for the Humanities

d. Article in a Book

Burghardt, G.M. (1984). On the origins of play. In P.K Smith (Ed.), *Play in animals and human* (pp. 5-42). Oxford, England: Basil Blackwell.

e. Report + Government Printing Office (GPO)

National Institute of Mental Health. (1990). *Clinical training in serious mental illness* (DHHS Publication No. ADM 90-1679). Washington, DC: U.S. Government Printing Office.

f. Television Broadcast

Crystal, L. (Executive Producer). (1993, October 11). The MacNeil/Lehrer news hour. [Television Broadcast]. New York and Washington, DC: Public Broadcasting Service.

g. Videotape

National Geographic Society (Producer). (1987). In the shadow of Vesuvius. [Videotape]. Washington, D.C: National Geographic Society

3. ONLINE JOURNALS, MAGAZINES, NEWSPAPERS, ETC. (PERIODICALS)

General Form- Online Periodicals:

Author, A. A., Author, B. B., & Author, C. C. (1999). Title of article. *Title of Periodical*, xx, xxx-xxx. Retrieve month day, year, from source.

a. Full- Text Article Retrieved from an Online Database

Second, B. (1997). Team roles and team performance: is there really a link? *Journal of Occupational and Organizational Psychology*, 70, 241-258. Retrieve June 6, 2001 from ABI/INFORM Global (Proquest) database.

Dykeman, B. F. (1994). The effect of motivational orientation, self- efficacy, and feedback condition on test anxiety. *Journal of Instructional Psychology*, 21 (2), 114-120. Retrieve June 4, 2001 from EBSSCOHost Academic Search Elite database.

Garza, A. (1999, March 17). Siesta put to rest: Mexican tradition under siege. *Boston Globe*, p. A2. Retrieve June 3, 2001 from Newsstand (Proquest) database.

Stevenson, W., K.I. Maton and D.M. Teti. (1999). Social support, relationship quality, and well-being among pregnant adolescents. *Journal of Adolescence*, 22(1), 109- 121. Retrieve June 3, 2001 from IDEAL database.

b. Article from E- journal website

Lodewijckx, H. F. M. (2001, May 23). Individual-group continuity in cooperation and competition under varying communication conditions. *Current Issues in Social Psychology*, 6 (12), 166-182. Retrieve September 14, 2001 from [http:// www.uiowa.edu/~grpproc/ crisp. 6. 12. Htm](http://www.uiowa.edu/~grpproc/crisp.6.12.Htm)

Jacobson, J. W., Mulick, J. A., & Schwartz, A. A. (1995). A history of facilitated communication: Science, pseudoscience, and antiscience: science working group on facilitated communication. *American Psychologist*, 50, 750-765. Retrieve June 6, 2001 from [http:// www.apa.org/journals/jacobson.html](http://www.apa.org/journals/jacobson.html)

4. ONLINE DOCUMENTS- Here are examples of APA style reference citations for other, non-periodical online documents retrieve from websites, Internet newsgroup, e-mail-based discussion groups, etc.

Author, A. A. (1999). *Title of work*. Retrieved month day, year, from source.

a. Stand-alone Online Document

NAACP (1999, February 25). *NAACP calls for Presidential order to halt police brutality crisis*. Retrieved June 3, 2001 from [http:// www.naacp.org/president/releases/police_brutality.htm](http://www.naacp.org/president/releases/police_brutality.htm)

b. Stand-alone Online Document + No Author Identified + No Date

Philippine Council for Agriculture, Forestry, and Natural Resources Research and Development. (2003). Retrieve July 20, 2004 from [http://www. Pacarrd.dost.gov.ph/news/press%20release/apr%2020003/pr7apr03html](http://www.Pacarrd.dost.gov.ph/news/press%20release/apr%2020003/pr7apr03html).

5. UNPUBLISHED DOCTORAL DISSERTATION

David, F.P. (1996). *Gender differentials in work responsibilities and decision-making participation at home and at work among college faculty members in the four universities in Iloilo City*. Unpublished doctoral dissertation, Central Philippine University, Iloilo City. Philippines.

Seneres, N. (1997). *Conflict management style of deans in the state universities and colleges in Region VI: Its relationship to job satisfaction and performance of faculty members*. Unpublished doctoral dissertation, Central Philippine University, Iloilo City, Philippines.

6. UNPUBLISHED MASTERS' THESIS

Calibjo, Mylene S. (2005). *Reading comprehension and other related factors as predictors of problem solving performance in college algebra*. Unpublished master's thesis, Central Philippine University, Iloilo City, Philippines.

Ordaniel, L. (2002). *Mathematics anxiety and achievement of marine engineering students of John B. Lacson Colleges Foundation, Molo-Inc*. Unpublished master's thesis, Central Philippine University, Iloilo City, Philippines.



DISCLAIMER FOR USE

This document is a draft copy of the Research Project (Thesis Writing) Guidebook that serves as a reference in the final preparation of the proposal and submission of the thesis. This is only intended for the 4th/5th year students of the College of Engineering and Technology of the Romblon State University who are taking-up the subject, Research Projects 1 and 2.

The preparation of the guidebook is based on the approved Research Manual of the university approved in 2010.

This document as a reference material is allowed for academic purposes only. However, commercial reproduction in any form (printing and digital formats) requires prior approval of the author.

Write your comments to:

ENGR. REYNALDO PEREZ-RAMOS

Associate Professor

College of Engineering and Technology

Romblon State University

Odiongan, Romblon

Philippines

Email: rsu.rpramos@gmail.com

Website: www.rsucivilengineering.weebly.com

Copyright October 2016